

D11 Series

Narrow body AC Drives



POWER RATINGS

3 x 380-480 V 1.5kw - 500kw

Versatile & Multifunctional

MPPT

Promoted V/Hz

SVC

ModBus

Detachable Control Panel

Multi-step Freq.

PID

S-curve

Simple PLC

2 Motor Switchover

Skip Frequency

V/Hz Separated Control

Common DC Bus

Mechanical Brake

Restart Upon Power Loss

Cycle-By-Cycle Current Limit

Motor Thermal Protection

Stall Protections

MPPT

...

AC DRIVE D11 SERIES

Start Torque@0.5HZ
150%

Overload Capability
200%

Ambient Temp °c
50

Speed Regulation
1:200

Ingress Protection
IP20

Speed accuracy ±
0.2%



TERMINAL

Analog Input x 2

Analog Output x 2

Relay Output x 2

Digital Input x 7

Open collector output x 2

Communication Port x1

MODEL

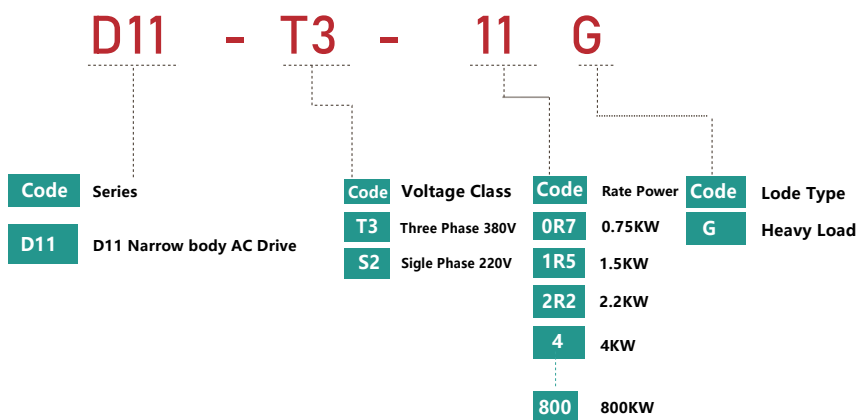

Anhui Zhongtuo Electric Co.,Ltd

Model:D11--T3--11G

Max Appli Motor: 11.0KW

Input:AC3PH 380-460V 50/60Hz 36.6/40.0A

Output:AC3PH 0-460V 0-400Hz 24.6/32.0A

Operating Temperature:-10℃~50℃

IP Protection:IP20 Mass:

S/N: 



ADD:No. 265, Suixi Road, Xiangshan District, Huaibei City, Anhui Province, China

Product Parameter

Model	Heavy load	Power Rating (kW)	Rated Output Current (Amps)	Rated Input Current (Amps) ^{1/4}	Applicable Motor (kW)	Model	Light load	Power Rating (kW)	Rated Output Current (Amps)	Rated Input Current (Amps) ^{1/4}	Applicable Motor (kW)
	H						L				
D11-S2-1R5G	H	1.5	7	12	1.5	D11-S2-2R2G	H	2.2	9.6	15	2.2
D11-T3-0R7G	H	0.75	2.3	3.6	0.75	D11-T3-75G	H	75	150	160	75
D11-T3-1R5G	H	1.5	4.1	6.4	1.5	D11-T3-90G	H	90	180	190	90
D11-T3-2R2G	H	2.2	5.5	8.7	2.2	D11-T3-110G	H	110	215	225	110
D11-T3-4G	H	4	9.4	14	4	D11-T3-132G	H	132	260	265	132
D11-T3-5R5G	H	5.5	12.6	20.7	5.5	D11-T3-160G	H	160	305	310	160
D11-T3-7R5G	H	7.5	18.5	26.5	7.5	D11-T3-185G	H	185	350	355	185
D11-T3-11G	H	11	24.6	36.6	11	D11-T3-200G	H	200	380	385	200
D11-T3-15G	H	15	32	40	15	D11-T3-220G	H	220	425	430	220
D11-T3-18R5P	H	18	38	47	18	D11-T3-250G	H	250	480	485	250
D11-T3-22G	H	22	45	56	22	D11-T3-280G	H	280	530	545	280
D11-T3-30G	H	30	60	70	30	D11-T3-315G	H	315	600	610	315
D11-T3-37G	H	37	75	80	37	D11-T3-350G	H	355	650	665	355
D11-T3-45G	H	45	92	95	45	D11-T3-400G	H	400	725	785	400
D11-T3-55G	H	55	115	128	55	D11-T3-500G	H	500	860	885	500

DIMENSIONS

Unit, mm

Model	P (kW)	H	W	D	Model	P (kW)	H	W	D
D11-S2-1R5G	1.5	170	78	142	D11-S2-2R2G	2.2	170	78	142
D11-T3-0R75G	0.75	170	78	142	D11-T3-75G	75	720	380	305.6
D11-T3-1R5G	1.5	170	78	142	D11-T3-90G	90	720	380	305.6
D11-T3-2R2G	2.2	170	78	142	D11-T3-110G	110	720	380	305.6
D11-T3-4G	4	212	95	158.7	D11-T3-132G	132	720	380	305.6
D11-T3-5R5G	5.5	212	95	158.7	D11-T3-160G	160	850	520	342.1
D11-T3-7R5G	7.5	240	140	187.7	D11-T3-185G	185	850	520	342.1
D11-T3-11G	11	240	140	187.7	D11-T3-200G	200	850	520	342.1
D11-T3-15G	15	322	205	206.5	D11-T3-220G	220	1090	650	455.6
D11-T3-18R5P	18	322	205	206.5	D11-T3-250G	250	1090	650	455.6
D11-T3-22G	22	322	205	206.5	D11-T3-280G	280	1090	650	455.6
D11-T3-30G	30	500	270	223.9	D11-T3-315G	315	1090	650	455.6
D11-T3-37G	37	500	270	223.9	D11-T3-350G	350	1280	750	435.6
D11-T3-45G	45	522	320	257.6	D11-T3-400G	400	1280	750	435.6
D11-T3-55G	55	522	320	257.6	D11-T3-500G	500	1280	750	435.6



AC DRIVE D11 SERIES

ANHUI ZHONGTUO ELECTRIC CO.,LTD
www.zoto-electric.com

ADD: No.265, Suixi Road, Xiangshan District, Huaibei City, Anhui Province, China
T: +86 180 5612 0995 M: admin@zoto-electric.com

All Rights © ZOTO